



External tangs :

■ Single or double, with one or two thread pins. External tangs are designed to take stemball fittings which are easily exchangeable with manual fittings. Single tangs are also used for runners.

Les capelages extérieurs :

■ Simple ou double, avec 1 ou 2 axes filetés. Les capelages extérieurs sont conçus pour recevoir des embouts à œil. Les capelages simples sont utilisés également pour bastaques.



**COMPLETE EXTERNAL TANGS (WITHOUT THREADED PIN, p.26 & 27)
CAPELAGES EXTÉRIEURS (SANS AXE FILETÉ, p. 26 & 27)**

■ Part numbers according to the wire diameter.
■ Références suivant \varnothing de câble



SINGLE TANG
/ CAPELAGE SIMPLE



DOUBLE TANG
CAPELAGE DOUBLE

\varnothing wire \varnothing câble	\varnothing pin \varnothing axe $\varnothing P$	STANDARD (SPARCRAFT RIGGING)		STANDARD (SPARCRAFT RIGGING)	
		Part number / Référence	A	Part number / Référence	A
$\varnothing 3$	$\varnothing 6$	31003002065	50	31003003065	50
$\varnothing 4$	$\varnothing 8$	31003002085	48	31003003085	48
$\varnothing 5$					
$\varnothing 6$	$\varnothing 12$	31003005125	81	31003006125	81
$\varnothing 7$					
$\varnothing 8$					
$\varnothing 10$	$\varnothing 16$	31003005165	105	31003006165	105
$\varnothing 12$	$\varnothing 18$	31003005185	120	31003006185	120
$\varnothing 12,7$					
$\varnothing 14$	$\varnothing 22$	31003005225	130	31003006225	130
$\varnothing 16$	$\varnothing 25$	31003005255	150	31003006255	150

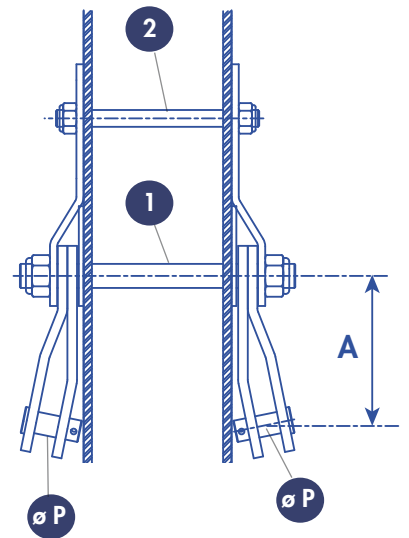

Threaded pin : see pages 26/27
Axe fileté : voir pages 26/27



LATERAL SHROUDS ATTACHMENTS / ANCRAGES LATÉRAUX

■ Determination of the thread pin diameter and part number according to the mast profil and the type of external tang. The three last digits correspond to the length of the thread pin.

■ Détermination de la référence et du diamètre de l'axe fileté (vendus séparément) suivant le profil de mât et le type de capelage. Les trois derniers chiffres de la référence correspondent à la longueur d'axe.

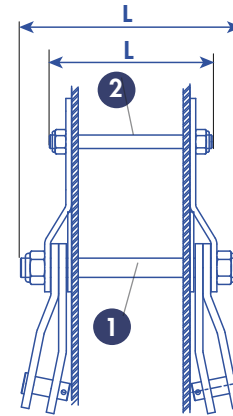

EXTERNAL TANGS COMPLETE KITS (without thread pin) / KIT COMPLETS CAPELAGES EXTÉRIEURS (sans axe fileté)

Wire ø ø Câble	ø 3 mm	ø 4-5 mm	ø 6-7-8 mm	ø 10 mm
SIMPLE	31003002065	31003002085	31003005125	31003005165
DOUBLE	31003003065	31003003085	31003006125	31003006165

STAINLESS STEEL THREADED PIN (Part number and dimensions)
/ AXE INOX FILETÉ (Références et dimensions)

PROFILE PROFIL ∨	Ø Thread pin and type / Ø et type d'axe traversant				
	①	①	①	②	①
	Ø 10	Ø 10	Ø 14	Ø 10	Ø 20
S 35	-	-	-	-	-
S50	4002 05 10 110	-	-	-	-
S67	4002 05 10 120	-	-	-	-
S80	4002 05 10 120	-	-	-	-
S137	4002 05 10 130	4002 05 10 138	-	-	-
S180	4002 05 10 138	4002 05 10 138	4002 05 14 167	-	-
S260	4002 05 10 154	4002 05 10 154	4002 05 14 183	-	-
S330	-	4002 05 10 154	4002 05 14 183	-	-
S400	-	4002 05 10 154	4002 05 14 183	-	-
S510	-	4002 05 10 162	4002 05 14 194	-	-
S622	-	-	4002 05 14 199	4002 05 10 172	4002 05 20 222
S830	-	-	4002 05 14 206	4002 05 10 172	4002 05 20 222
S1060	-	-	4002 05 14 206	4002 05 10 177	4002 05 20 238
S1170	-	-	4002 05 14 233	4002 05 10 208	4002 05 20 260
S1210	-	-	4002 05 14 222	4002 05 10 188	4002 05 20 238
S1395	-	-	4002 05 14 222	4002 05 10 188	4002 05 20 238
S1540	-	-	4002 05 14 233	4002 05 10 208	4002 05 20 249
S1630	-	-	4002 05 14 253	4002 05 10 220	4002 05 20 267
S2100	-	-	4002 05 14 253	4002 05 10 220	4002 05 20 267
S3410	-	-	-	4002 05 10 240	4002 05 20 289
S4600	-	-	-	4002 05 10 260	4002 05 20 325

FOR FURLING MASTS / POUR MÂTS ENROULEURS

S265E	-	4002 05 10 141	-	-	-
S365E	-	4002 05 10 162	4002 05 14 188	-	-
S560E	-	-	4002 05 14 183	-	-
S760E	-	-	4002 05 14 194	4002 05 10 162	4002 05 20 222
S980E	-	-	4002 05 14 199	4002 05 10 177	4002 05 20 227
S1420E	-	-	4002 05 14 222	4002 05 10 188	4002 05 20 238
S1980E	-	-	4002 05 14 233	4002 05 10 208	4002 05 20 249



Stainless steel threaded pin PART NUMBERS
RÉFÉRENCES des axes inox filetés

Part number Reference	Ø Pin Diameter Ø diamètre d'axe	L =Length of the pin L = Longueur d'axe (mm)
4002 05	XX	XXX

EXTERNAL TANGS COMPLETE KITS (without thread pin)

KIT COMPLETS CAPELAGES EXTÉRIEURS (sans axe fileté)

Wire Ø Ø Câble	Ø 12 mm - 12,7 mm	Ø 14 mm	Ø 16 mm
SIMPLE	31003005185	31003005225	31003005255
DOUBLE	31003006185	31003006225	31003006255

STAINLESS STEEL THREADED PIN (Part number and dimensions)
/ AXE INOX FILETÉ (Références et dimensions)

PROFILE PROFIL ∨	Ø Thread pin and type / Ø et type d'axe traversant					
	② Ø 14	① Ø 20	② Ø 14	① Ø 22	② Ø 16	① Ø 22
S 35	-	-	-	-	-	-
S50	-	-	-	-	-	-
S67	-	-	-	-	-	-
S80	-	-	-	-	-	-
S137	-	-	-	-	-	-
S180	-	-	-	-	-	-
S260	-	-	-	-	-	-
S330	-	-	-	-	-	-
S400	-	-	-	-	-	-
S510	-	-	-	-	-	-
S622	-	-	-	-	-	-
S830	-	-	-	-	-	-
S1060	4002 05 14 194	4002 05 20 249	4002 05 14 194	4002 05 22 255	-	-
S1170	4002 05 14 222	4002 05 20 278	4002 05 14 222	4002 05 22 295	-	-
S1210	4002 05 14 199	4002 05 20 260	4002 05 14 199	4002 05 22 268	4002 05 16 220	4002 05 22 295
S1395	4002 05 14 199	4002 05 20 260	4002 05 14 199	4002 05 22 268	4002 05 16 220	4002 05 22 295
S1540	4002 05 14 222	4002 05 20 278	4002 05 14 222	4002 05 22 295	4002 05 16 230	4002 05 22 295
S1630	4002 05 14 233	4002 05 20 289	4002 05 14 233	4002 05 22 295	4002 05 16 250	4002 05 22 315
S2100	4002 05 14 233	4002 05 20 289	4002 05 14 233	4002 05 22 295	4002 05 16 250	4002 05 22 315
S3410	4002 05 14 253	4002 05 20 325	4002 05 14 253	4002 05 22 315	4002 05 16 285	4002 05 22 350
S4600	4002 05 14 268	4002 05 20 325	4002 05 14 268	4002 05 22 315	4002 05 16 285	4002 05 22 350

FOR FURLING MASTS / POUR MÂTS ENROULEURS

S265E	-	-	-	-	-	-
S365E	-	-	-	-	-	-
S560E	-	-	-	-	-	-
S760E	-	-	-	-	-	-
S980E	4002 05 14 188	4002 05 20 249	-	-	-	-
S1420E	4002 05 14 200	4002 05 20 260	4002 05 14 200	4002 05 20 268	-	-
S1980E	4002 05 14 222	4002 05 20 278	4002 05 14 222	4002 05 22 295	4002 05 16 230	4002 05 22 295