

WELDED MASTHEAD / TÊTE DE MÂT SOUDÉE

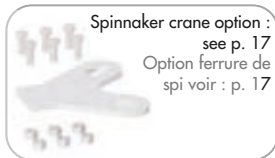
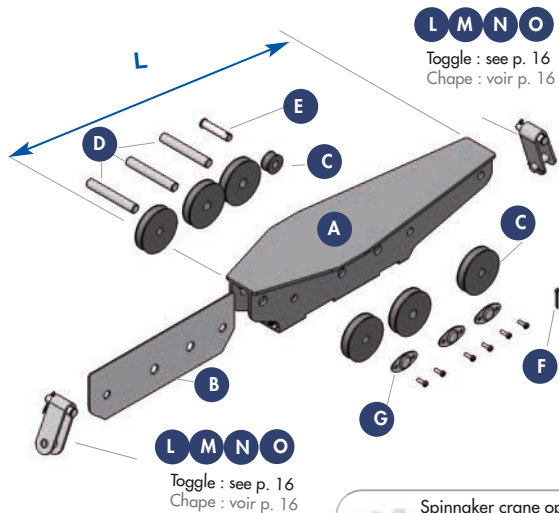

MAST SECTION / MÂT		S265E	S980E	S1980E						
Pict/ Repères	SECTION n°	BODY n°	3	3	6					
	LONGUEUR mm	LENGTH mm	424	520	680					
	CODE COMPLET	COMPLETE CODE	30003014245	30003015185	30006016805					
	DESIGNATION	DESCRIPTION	CODE	QT	CODE	QT	CODE	QT		
A	CORPS	BODY	30003014243	1	30003015182	1	30006016802	1		
B	CLOISON	CHEEK	30003114243	1	30003115185	1	-			
C	REAS	SHEAVES			48510651625	2	48510902125	3		
					48510651625	6	48510501625	1	48511102125	3
					48510401516	1	48685151200	4	-	
D	AXE DROIT	PIN			40020112090	2	40020112090	1	40201181052	1
							40020112120	2	40020118120	1
									40201181322	1
E	AXE INOX ÉPAULÉ	CLEVIS PIN	40020212052	2	40020212052	1	40020218078	1		
F	GOUPILLE	COTTER PIN	28803032320	2	28803032200	1	28803040400	1		
G	CACHE AXE	PIN PROTECT.	41201020105	2	41201020105	3	41201020205	1		
E	RONDELLE	WASHER					28602318030	1		
-	VIS	SCREW					28600704020	2		
-	BOUCHON FEU	LIGHTS COVER					43093000001	1		