

# ■ Masthead non tapered for masthead rig / Tête de mât non rétreint pour gréement en tête

## BOLTED MASTHEAD / TÊTE DE MÂT BOULONNÉE

MAST SECTION / MAT		S365E		S560E		S760E		S1420E		
Pic / Repères	SECTION n°	BODY n°		3		3		6		
	LONG. mm	LENGTH mm		445		455		605		
	CODE COMPLET	COMPLETE CODE		30003B20085		30003B20115		30003B20135		30006B20195
DESIGNATION	DESCRIPTION	CODE	Qté	CODE	Qté	CODE	Qté	CODE	Qté	
A	CORPS	BODY	30003B21082	1	30003B21112	1	30003B21132	1	30006B21192	1
B	CLOISON	CHEEK	30003122553	1	30003114553	1	30003122803	-	-	-
Parts kit / Kit composants			30003B07080	1	30003B27113	1	30003B27130	1	30006B07190	1
C	REAS	SHEAVES	48510401516	1	48685151200	2	48685151200	4	48510652125	2
	REAS	SHEAVES	48510651625	1	48660151200	4	48510651625	2	48510902125	4
	REAS	SHEAVES	48660151200	5	48510401516	1	48510401516	1	-	1
D	AXE DROIT	PIN	40020212052	2	40020112060	1	40020212052	1	40201181052	1
E	AXE ÉPAULÉ	CLEVIS PIN	40020112090	2	40020112060	2	40020112080	1	40020218078	1
					40020112090	1	40020112090	2	-	2
F	GOUPILLE	COTTER PIN	28803032200	2	28803032200	1	28803032200	1	28803032320	1
Assembly kit / Kit assemblage					30003B02000			1	30006B02015	1
G	PLOT	PULLING STUD			30003B03014			2	30006210014	2
H	VIS	SCREW			28600110070			2	28600114090	2
i	RIVET	RIVET			29002248140			2	29004164180	2
J	RONDELLE	WASHER			28601010000			2	28602014000	2
K	ÉCROU FREIN	SAFETY NUT			28600510000			2	28600514000	2

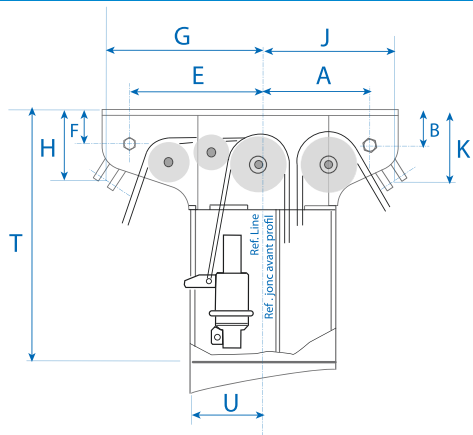
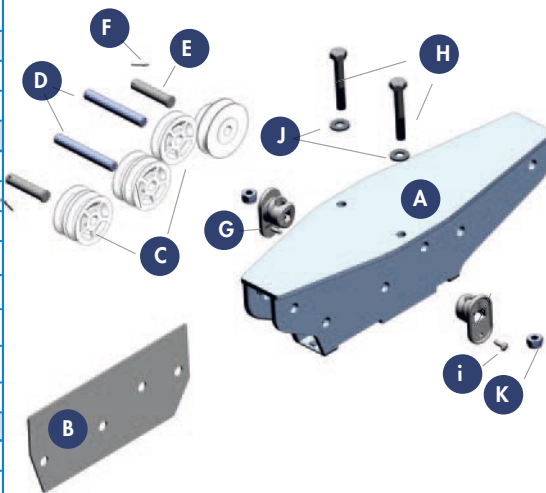

## SPECIFICATIONS / CARACTÉRISTIQUES DIMENSIONNELLES

MAST SECTION MÂT	MASTHEAD TÊTE DE MÂT PART NUMBER REFERENCE	ø TOGGLES ø AXE CHAPE	DIMENSIONS					
			G	H	J	K	T	U
S 265 E	30003014245	ø10, ø12	229	86	171	88	350	95
S 365 E	30003B20085	ø12	239	86	181	88	350	90
S 560 E	30003B20115	ø12, ø16	262	86	169	88	450	91
S 760 E	30003B20135	ø12, ø16	271	86	197	88	480	122
S 980 E	30003015185	ø12, ø16, ø18	276	86	218	88	500	115
			E	F	A	B	T	U
S 1420 E	30006B00195	ø12, ø16, ø18	303	42	242	42	500	118
S 1980 E	30006016805	ø16 mini	363	40	247	40	500	140