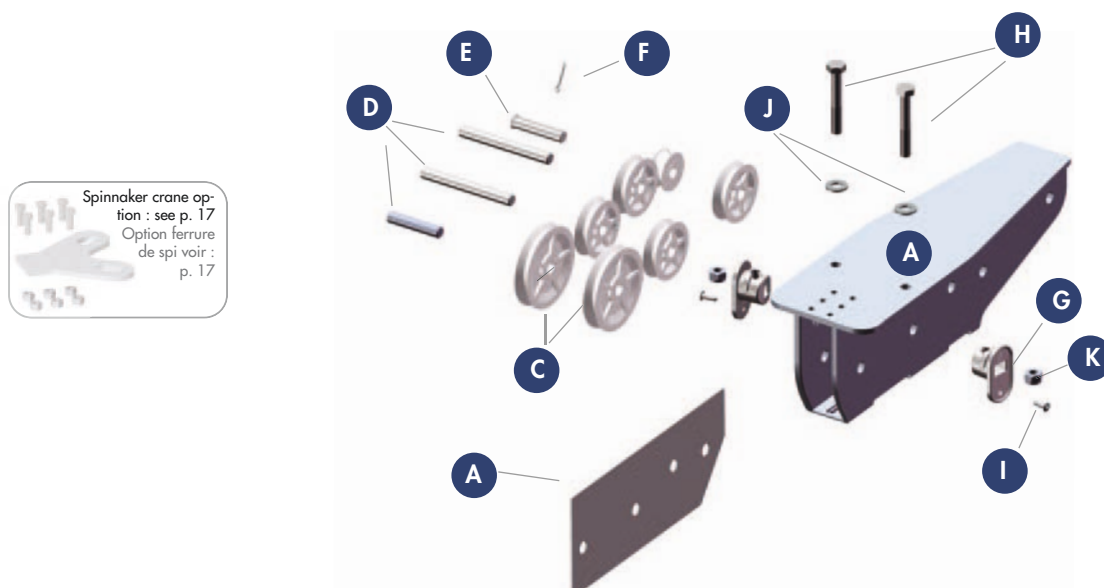

**■ Masthead non tapered for fractionned rigs / Tête de mât non rétreint pour gréement fractionné**

**BOLTED MASTHEAD / TÊTE DE MÂT BOULONNÉE**

MAST SECTION / MÂT		S265E	S365E	S560E	S760E	S980E	S1420E	S1980E								
Pict / Repères	SECTION n°	4		3		3		3		6		6				
	LONG. mm	374		397		405		446		468		533		614		
	CODE COMPLET	30004B00055		30003B00085		30003B00115		30003B00135		30003B00155		30006B00195		30006B00213		
DESIGNATION	DESCRIPTION	CODE	Qt	CODE	Qt	CODE	Qt	CODE	Qt	CODE	Qt	CODE	Qt	CODE	Qt	
A	CORPS	BODY	30004B01052	1	30003B01082	1	30003B01112	1	30003B01132	1	30003B01152	1	30006B01192	1	30006B01223	1
B	CLOISON	CHEEK	30004163743	1	30003163973	1	30003164053	1	30003122803	1	30003153955	1	-	1	-	1
Parts kit / Kit composants			30004B07040	1	30003B07080	1	30003B07110	1	30003B07130	1	30006B07190	1	30006B07190	1	30006B04617	1
C	REAS	SHEAVES	48660131000	3	48510401516	1	48685151200	2	48685151200	4	48510501625	1	48510652125	2	4851102125	3
	REAS	SHEAVES	48510251225	1	48510651625	1	48660151200	4	48510651625	2	48510651625	2	48510902125	4	48510902125	3
	REAS	SHEAVES	48510601225	3	48660151200	5	48510401516	1	48510401516	1	48510801525	4	-	-	-	-
D	AXE DROIT	PIN	40020110060	1	40020212052	2	40020212052	1	40020212052	1	40020112080	1	40201181052	2	40201181052	1
									40020112120	2	40020118069	1				
E	AXE ÉPAULÉ	CLEVIS PIN	40020210040	1	40020112090	2	40020112060	2	40020112080	1	40020212052	1	40020218078	1	40020218078	1
							40020112105	1	40020112105	2						
F	GOUPILLE	COTTER PIN	28803032200	1	28803032200	2	28803032200	1	28803032200	1	28803032200	1	28803032320	1	28803032320	1
Assembly kit / Kit assemblage			30004B02015	1	30003B02000						1	30006B02015				1
G	PLOT	PULLING STUD	30004B03014	2	30003B03014						2	30006B03014				2
H	VIS	SCREW	28600108055	2	28600110070						2	28600114090				2
i	RIVET	RIVET	29002248140	2	29002248140						2	29004164180				2
J	RONDELLE	WASHER	28601008000	2	28601010000						2	28602014000				2
K	ÉCROU FREIN	SAFETY NUT	28600508000	2	28600510000						2	28600514000				2

**SPECIFICATIONS / CARACTÉRISTIQUES DIMENSIONNELLES**

MAST SECTION MÂT	MASTHEAD TÊTE DE MÂT Part number Référence	Ø TOGGLES Ø AXE CHAPE	DIMENSIONS			
			G	H	T	U
S 265 E	30004B00055	Ø10, Ø12	225	86	350	95
S 365 E	30003B00085	Ø12	239	86	350	90
S 560 E	30003B00115	Ø12, Ø16	240	86	450	91
S 760 E	30003B00135	Ø12, Ø16	271	86	480	122
S 980 E	30003B00155	Ø12, Ø16, Ø18	278	86	500	115
			E	F	T	U
S 1420 E	30006B00195	Ø12, Ø16, Ø18	303	42	500	118
S 1980 E	30006B00213	Ø16 mini	360	40	500	140

