

MASTHEADS FOR FURLING MASTS / TÊTES DE MÂT ENROULEUR

■ Masthead non tapered for masthead rig / Tête de mât non rétreint pour gréement en tête

BOLTED MASTHEAD / TÊTE DE MÂT BOULONNÉE

MAST SECTION / MÂT		S365E	S560E	S760E	S1420E					
Pic/ Repères	SECTION n°	3		3						
	LONG. mm	445		455						
	CODE COMPLET	30003B20085		30003B20115						
	DESIGNATION	DESCRIPTION	CODE	Qt	CODE	Qt	CODE	Qt	CODE	Qt
A	CORPS	BODY	30003B21082	1	30003B21112	1	30003B21132	1	30006B21192	1
B	CLOISON	CHEEK	30003122553	1	30003114553	1	30003122803	-	-	-
Parts kit / Kit composants			30003B07080	1	30003B27113	1	30003B27130	1	30006B07190	1
C	REAS	SHEAVES	48510401516	1	48685151200	2	48685151200	4	48510652125	2
	REAS	SHEAVES	48510651625	1	48660151200	4	48510651625	2	48510902125	4
	REAS	SHEAVES	48660151200	5	48510401516	1	48510401516	1	-	1
D	AXE DROIT	PIN	40020212052	2	40020112060	1	40020212052	1	40201181052	1
E	AXE ÉPAULÉ	CLEVIS PIN	40020112090	2	40020112060	2	40020112080	1	40020218078	1
			40020112090	1	40020112090	2	-	2	-	2
F	GOUPILLE	COTTER PIN	28803032200	2	28803032200	1	28803032200	1	28803032320	1
Assembly kit / Kit assemblage			30003B02000			1	30006B02015			1
G	PLOT	PULLING STUD				2	30006210014			2
H	VIS	SCREW				2	28600114090			2
i	RIVET	RIVET				2	29002248140			2
J	RONDELLE	WASHER				2	28601010000			2
K	ÉCROU FREIN	SAFETY NUT				2	28600510000			2

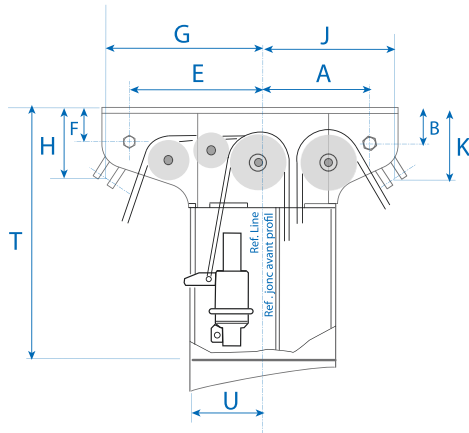
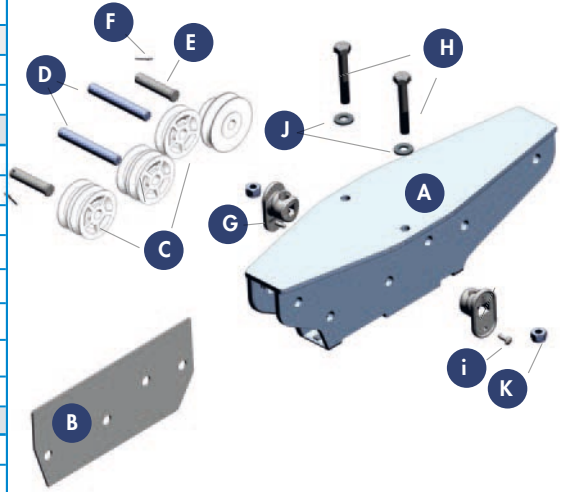

SPECIFICATIONS / CARACTÉRISTIQUES DIMENSIONNELLES

MAST SECTION MÂT	MASTHEAD TÊTE DE MÂT PART NUMBER REFERENCE	ø TOGGLES ø AXE CHAPE	DIMENSIONS					
			G	H	J	K	T	U
S 265 E	30003014245	ø10, ø12	229	86	171	88	350	95
S 365 E	30003B20085	ø12	239	86	181	88	350	90
S 560 E	30003B20115	ø12, ø16	262	86	169	88	450	91
S 760 E	30003B20135	ø12, ø16	271	86	197	88	480	122
S 980 E	30003015185	ø12, ø16, ø18	276	86	218	88	500	115
			E	F	A	B	T	U
S 1420 E	30006B00195	ø12, ø16, ø18	303	42	242	42	500	118
S 1980 E	30006016805	ø16 mini	363	40	247	40	500	140

WELDED MASTHEAD / TÊTE DE MÂT SOUDÉE

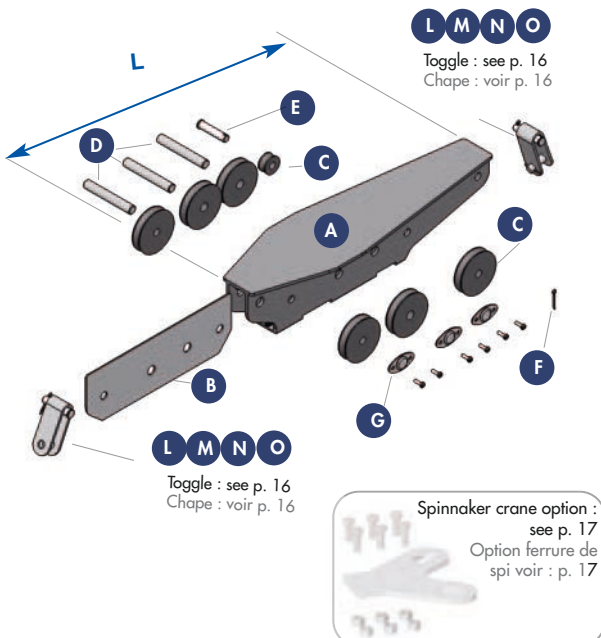

MAST SECTION / MÂT		S265E	S980E	S1980E				
Pic/ Repères	SECTION n°	3		6				
	LONGUEUR mm	424		680				
	CODE COMPLET	30003014245		30003015185				
	DESIGNATION	DESCRIPTION	CODE	Qt	CODE	Qt	CODE	Qt
A	CORPS	BODY	30003014243	1	30003015182	1	30006016802	1
B	CLOISON	CHEEK	30003114243	1	30003115185	1	-	-
C	REAS	SHEAVES			48510651625	2	48510902125	3
			48510651625	6	48510501625	1	48511102125	3
			48510401516	1	48685151200	4	-	-
D	AXE DROIT	PIN	40020112090	2	40020112090	1	40201181052	1
					40020112120	2	40020118120	1
							40201181322	1
E	AXE INOX ÉPAULÉ	CLEVIS PIN	40020212052	2	40020212052	1	40020218078	1
F	GOUPILLE	COTTER PIN	28803032320	2	28803032200	1	28803040400	1
G	CACHE AXE	PIN PROTECT.	41201020105	2	41201020105	3	41201020205	1
E	RONDELLE	WASHER					28602318030	1
-	VIS	SCREW					28600704020	2
-	BOUCHON FEU	LIGHTS COVER					43093000001	1

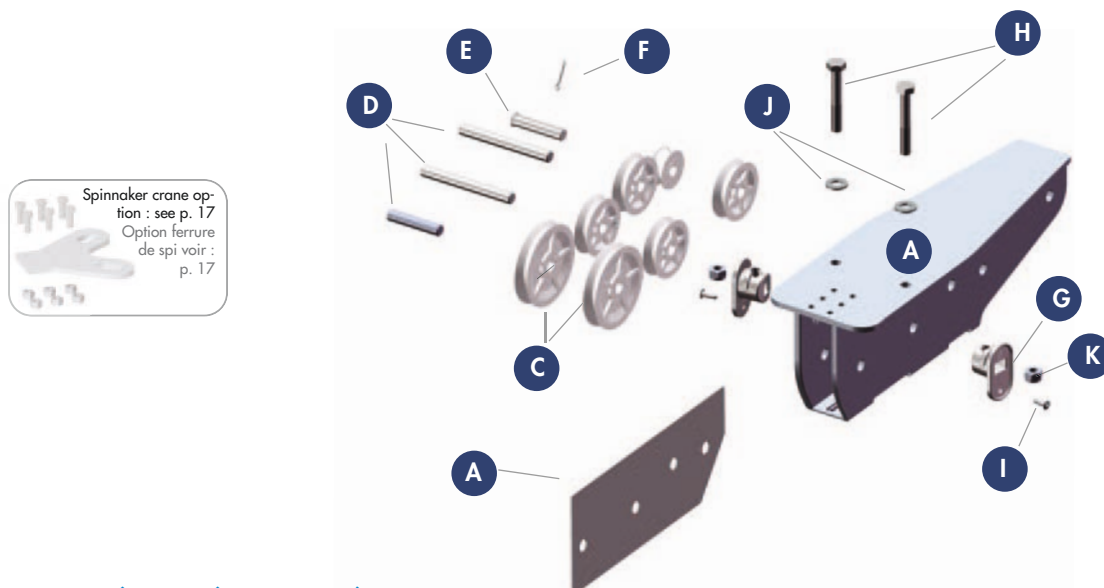
■ Masthead non tapered for fractionned rigs / Tête de mât non rétreint pour gréement fractionné

Spinner crane option : see p. 17
Option ferrure de spi voir : p. 17

BOLTED MASTHEAD / TÊTE DE MÂT BOULONNÉE

MAST SECTION / MÂT		S265E	S365E	S560E	S760E	S980E	S1420E	S1980E								
Pict / Repères	SECTION n°	4		3		3		6								
	LONG. mm	374		397		405		446								
	CODE COMPLET	30004B00055		30003B00085		30003B00115		30003B00135								
	DESIGNATION	DESCRIPTION	CODE	Qt	CODE	Qt	CODE	Qt	CODE	Qt	CODE	Qt	CODE	Qt		
A	CORPS	BODY	30004B01052	1	30003B01082	1	30003B01112	1	30003B01132	1	30003B01152	1	30006B01192	1	30006B01223	1
B	CLOISON	CHEEK	30004163743	1	30003163973	1	30003164053	1	30003122803	1	30003153955	1	-	1	-	1
Parts kit / Kit composants			30004B07040	1	30003B07080	1	30003B07110	1	30003B07130	1	30006B07190	1	30006B07190	1	30006B04617	1
C	REAS	SHEAVES	48660131000	3	48510401516	1	48685151200	2	48685151200	4	48510501625	1	48510652125	2	4851102125	3
	REAS	SHEAVES	48510251225	1	48510651625	1	48660151200	4	48510651625	2	48510651625	2	48510902125	4	48510902125	3
	REAS	SHEAVES	48510601225	3	48660151200	5	48510401516	1	48510401516	1	48510801525	4	-	-	-	-
D	AXE DROIT	PIN	40020110060	1	40020212052	2	40020212052	1	40020212052	1	40020112080	1	40201181052	2	40201181052	1
									40020112120	2	40020118069	1				
E	AXE ÉPAULÉ	CLEVIS PIN	40020210040	1	40020112090	2	40020112060	2	40020112080	1	40020212052	1	40020218078	1	40020218078	1
							40020112105	1	40020112105	2						
F	GOUPILLE	COTTER PIN	28803032200	1	28803032200	2	28803032200	1	28803032200	1	28803032200	1	28803032320	1	28803032320	1
Assembly kit / Kit assemblage			30004B02015	1	30003B02000						1	30006B02015				1
G	PLOT	PULLING STUD	30004B03014	2	30003B03014						2	30006B03014				2
H	VIS	SCREW	28600108055	2	28600110070						2	28600114090				2
i	RIVET	RIVET	29002248140	2	29002248140						2	29004164180				2
J	RONDELLE	WASHER	28601008000	2	28601010000						2	28602014000				2
K	ÉCROU FREIN	SAFETY NUT	28600508000	2	28600510000						2	28600514000				2

SPECIFICATIONS / CARACTÉRISTIQUES DIMENSIONNELLES

MAST SECTION MÂT	MASTHEAD TÊTE DE MÂT Part number Référence	Ø TOGGLES Ø AXE CHAPE	DIMENSIONS			
			G	H	T	U
S 265 E	30004B00055	Ø10, Ø12	225	86	350	95
S 365 E	30003B00085	Ø12	239	86	350	90
S 560 E	30003B00115	Ø12, Ø16	240	86	450	91
S 760 E	30003B00135	Ø12, Ø16	271	86	480	122
S 980 E	30003B00155	Ø12, Ø16, Ø18	278	86	500	115
			E	F	T	U
S 1420 E	30006B00195	Ø12, Ø16, Ø18	303	42	500	118
S 1980 E	30006B00213	Ø16 mini	360	40	500	140

