









► MÂTS ENROULEURS / STOWAY MASTS

PROFILS PROFILES	DIMENSIONS mm	I X'X cm 4	I Y'Y cm 4	POIDS WEIGHT Kg / ml	EPAISSEUR THICKNESS mm	RALINGUE BOLT ROPE mm	CAVITÉ CAVITY Ø mm
I 265 E 	116 x 180	265	560	4,9	2,8	Ø 6,5	Ø 90
I 365 E 	124 x 200	365	760	5,8	3,2	Ø 6,5	Ø 90
F 560 E 	118 x 220	510	1320	6,9	3,5	Ø 7	Ø 100
F 760 E 	128 x 253	760	2220	8,96	3,9	Ø 7	Ø 115
F 980 E 	140 x 277	1039	3252	10,7	4,5	Ø 7	Ø 115
F 1410 E 	157 x 305	1410	4490	12,8	5	Ø 7	Ø 140
F 1980 E 	171 x 335	1980	5650	15,9	5,5	Ø 7	Ø 150
F 2600 E 	183 x 368	2650	7320	17,6	4,5 / 5,5	Ø 6	Ø 160

► INFORMATIONS VOILIERS / SAILMAKERS INFORMATION

Sections	L mm	h mm	H mm	Ø tube intérieur Ø furling mm	Ralingue Bolt rope mm	d mm	A mm	Coulisseaux Voile de cap Sliders - Storm sail
I 265 E	350	40	(6%xE)+h	Ø 33	Ø 6,5 fini / finish	20	130	800 - 400 - N° 30
I 365 E	350	40	(6%xE)+h	Ø 33	Ø 6,5 fini / finish	20	130	800 - 400 - N° 30
F 560 E	450	70	(6%xE)+h	Ø 33	Ø 7 fini / finish	70	200	800 - 400 - N° 30
F 760 E	480	90	(7%xE)+h	Ø 33	Ø 7 fini / finish	90	250	800 - 400 - N° 30
F 980 E	500	90	(7%xE)+h	Ø 33	Ø 7 fini / finish	90	250	800 - 400 - N° 30
F 1410 E	500	90	(7%xE)+h	Ø 33	Ø 7 fini / finish	90	250	800 - 400 - N° 30
F 1980 E	550	50	(7%xE)+h	Ø 45	Ø 7 fini / finish	115	250	CGV 23 - HA 91
F 2600 E	550	50	(7%xE)+h	Ø 45	Ø 6 fini / finish	115	250	CGV 23 - HA 91

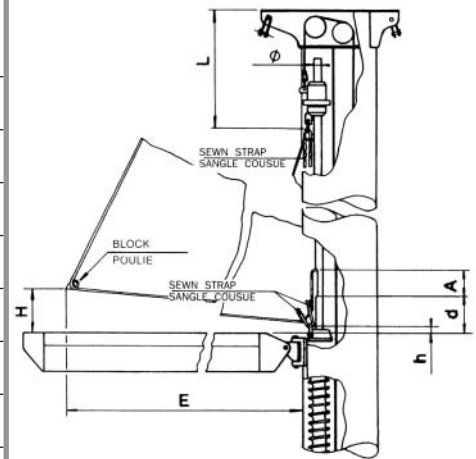

► CARACTÉRISTIQUES DIMENSIONNELLES / SPECIFICATIONS

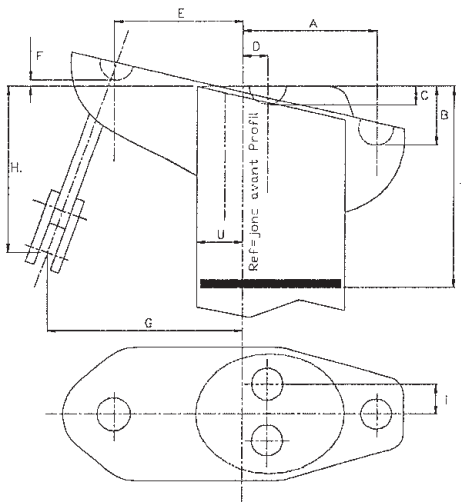

MÂTS ENROULEUR OcéAN / FURLING MASTS OcéAN

PROFIL/PROFILE	REF.	A	B	C	D	E	F	G	H
I 265 E	30001042655	118	110	20	12	133	10	166	79
I 365 E	30001043655	128	115	25	22	233	5	156	84

PROFIL/PROFILE	I	T	U
I 265 E	33	350	80
I 365 E	33	350	90

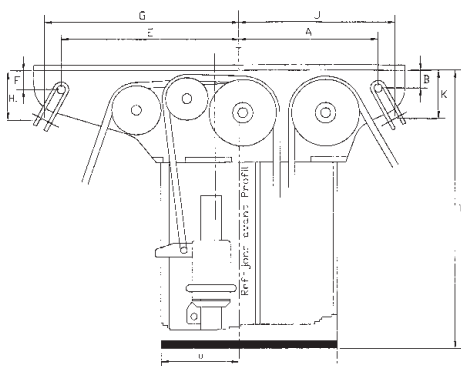

MÂTS ENROULEUR PERFORMANCE / FURLING MASTS PERFORMANCE

PROFIL/PROFILE	REF.	G	H	J	K	T	U
F 560 E	30003025605	205	85	195	95	450	91
F 760 E	30003027605	250	80	200	80	480	110
F 980 E	30003029805	260	78	220	85	500	115
		E	F	A	B	T	U
F 980 E	30006025805	265	40	230	40	500	115
F 1410 E	30006026305	285	40	273	40	500	126
F 1980 E	30006026705	350	44	250	44	550	140
F 2600 E	30006027105	330	44	290	44	550	172