



S RANGE MASTS

Mast step & Deck collars

ACCESSORIES FOR MAST STEPS & DECK COLLARS

NEW



ashackle.

Mast step blocks

- These blocks are made of a brand new material – GVX – designed from high resistance fiberglass. They can be hooked with a toggle, an articulated toggle, or

Mast step blocks

Sizes (mm)	35	50	60	80
Breaking loads (kg)	820	1200	2000	3000
Working loads (kg)	410	600	1200	1800
Rope diameter (mm)	3-8	4-12	6-14	8-18

Pins, block springs

- Stainless steel clevis pin (12 x 34; 14 x 39), or threaded (12 x 27; 14 x 26; 12 x 42; 14 x 51)
- Springs sizes 35, 50 et 60 mm (Lg 40) et and size 80 mm (Lg 50), for mast steps.



Stainless steel clevis pin

Springs for maststeps



Pad eyes

- Stainless steel pad eyes for mast step blocks ø10, screwed pad eyes ø12;
- Mast steps and deck collars are delivered with a vand pad eye. Vang pad eyes A45 are sold separately (ø10 holes)..



pad eyes for mast step blocks

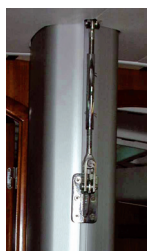

Deck tie rods

- The deck tie rods (one or several depending on the size of the mast) are mounted between the collar and the stepped part of the mast. As the halyards are attached to the collar on the deck, the tie rods compensate for the load they exert.

Deck tie rod						
Model	M6	M6	M10	M12	M14	M14
Length (mm)	140	230	335	330	410	375 RTT70



Deck tie rod

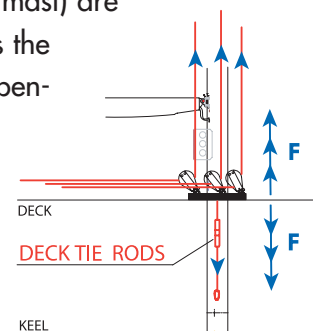

INTERNAL WATERPROOF SYSTEMS

- The Sparcraft internal system guarantees keel stepped mast to be watertight. The system is installed just below the lowest halyard exit. This exit doubles as the drain.

silicone injection

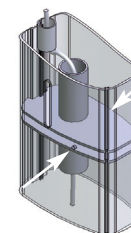

INTERNAL SPLICES

- All our sections can incorporate a splice, determined by the constraints of transport or production (size of the anodizing tank : 21.5 m in the USA and 19.50 m in France).

Internal splice					
Mast sections	S35	S67	S80 - S137 - S180 S260 - S305 - S330 S385 - S460 - S580	S622 - S740- S830- S1060 - S1395 - S1395	S2100 - S2390 S3360 - S4600
Splice length (mm)	400	600	800	1200	1500

